

SOCKET/FEMALE CONTACT CAVITY IDENTIFICATION ON REAR

PIN/MALE CONTACT CAVITY IDENTIFICATION ON REAR

NOTES: 2:1

1. MARKED WITH DEUTSCH PART No., DEUTSCH (HASTINGS) CAGE CODE AND DATE CODE.

PART NUMBER EXAMPLE:

D369 - R 9 9 - N S 1

BASIC PART No. _____
SHELL STYLE (R = INLINE RECEPTACLE) _____
SHELL SIZE _____
CONTACT QTY (9 = 9 x #22's) _____
CONTACT CONFIGURATION 4. _____
CONTACT TYPE (P = PIN, S = SKT) _____
SHELL KEYING _____

2. PERFORMANCE:
TEMPERATURE RANGE : -55°C TO +175°C. INSULATION RESISTANCE : ≥5000 MΩ.
DIELECTRIC WITHSTAND: 1000VRMS, <2mA. SEALING: 15KM(50000FT) ALTITUDE / IP67
DURABILITY : 500 MATING CYCLES MIN. FLUID RESISTANCE: I.A.W. EN2591-315.
FLAMMABILITY, SMOKE AND TOXICITY: I.A.W. FAR 25.853 APPENDIX F.

3. INSERTION/EXTRACTION TOOL (M81969/14-01 OR EQUIVALENT) SUPPLIED SEPARATELY.

4. Contact Configuration	Contact Description	Contact P/N (OR EQUIVALENT)		Crimp Positioner		Crimp Tool	Wire Accommodation	Current Rating
		Pin	Socket	Pin	Socket			
0		NO CONTACTS SUPPLIED						
1	CRIMP, COPPER WIRE	38941-22	38946-22	M22520/2-09	M22520/2-06	M22520/2-01	22-28 AWG	5A (22 AWG)
2	CRIMP, ALUMINIUM WIRE	200-1042-22	200-1142-22	KAL2		ALNP 22-A	22 AWG	5A
3	CRIMP, COPPER WIRE (ENLARGED WIRE)	182-0860-22	182-0862-22	M22520/2-09	M22520/2-06	M22520/2-01	20-24 AWG	5A (20 AWG)

5. MATERIALS:

COMPONENT	MATERIAL (FINISH: NONE IN ALL CASES)
SEALS	SILICONE / FLUOROSILICONE BLEND RUBBER PER AMS-R-25988 TYPE II, CLASS I, GRADE 40
BODY / INSERT COMPONENTS	POLYETHERIMIDE, 10% GLASS FILLED PER ASTM D 5205 or POLYETHERETHERKETONE, 450G, PER MIL-P-46183 TYPE I

6. MAXIMUM WEIGHT (WITHOUT CONTACTS):
2.0g (SKT INSERT), 1.9g (PIN INSERT).

AB	DUK-65685	RBC	HD	RBC	GLB	12/06/2015
ISSUE	CHANGE NOTE	DRAWN	CHECKED	APP. ENG.	APP. MARKETING	DATE

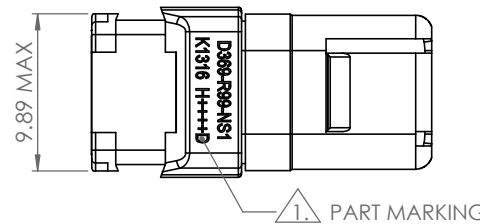
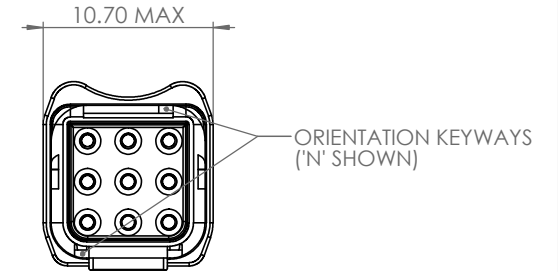
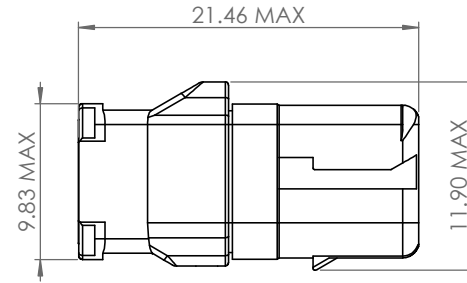

KEYWAY TABLE

ORIENTATION	COLOUR
N	BLACK
A	DARK RED
B	DARK BLUE
C	DARK GREEN
D	YELLOW

SHELL COLOUR IS KEYING DEPENDENT (SEE TABLE)

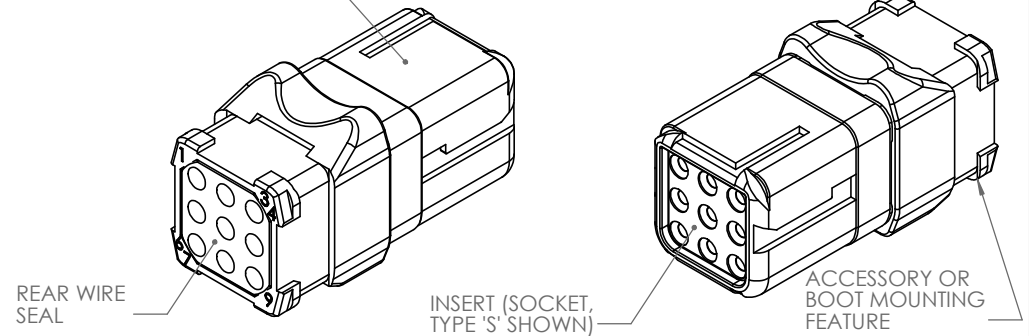

MATERIAL	SEE NOTES	THIS INFORMATION IS CONFIDENTIAL AND PROPRIETARY TO TYCO ELECTRONICS CORPORATION AND ITS WORLDWIDE SUBSIDIARIES AND AFFILIATES (TE). IT MAY NOT BE DISCLOSED TO ANYONE, OTHER THAN TE PERSONNEL, WITHOUT AUTHORIZATION FROM TE (www.TE.com).	 ST LEONARDS ON SEA, EAST SUSSEX, TN38 9RF TEL. +44 (0)1424 852721
HEAT TREATMENT & FINISH	PACKAGING		
SCALE	3:1		
DIMENSIONS IN MILLIMETRES UNLESS OTHERWISE STATED		TITLE	D369 INLINE RECEPTACLE, SHELL SIZE 9, 9 WAY
		TYPE	CUSTOMER DRAWING
		DRAWING NUMBER	611253-9-ENV